

WE WALK ALONGSIDE THE WORLD  
Stock Code: 300415

Designed by Yizumi, December 2022

**YIZUMI** 伊之密

FF

**FF Series Electric  
Injection Molding Machine**  
(90T-1380T)

**Yizumi Precision Molding Technology Co., Ltd.**

Address: No.12 Shunchang Road, Shunde, Foshan, Guangdong 528300, China  
TEL:86-757-2921 9800 86-757-2926 5150(overseas) www.yizumi.com

Disclaimer:

- 1.YIZUMI reserves the right to modify the product description in the catalogue. Specification might be changed without prior notice.
- 2.The picture in the catalogue is for reference only. The real object should be considered as final.
- 3.The data in the catalogue is obtained from internal testing in YIZUMI laboratory.  
Please refer to the actual machine for the final data. YIZUMI reserves the right of final interpretation upon disputes and ambiguities.





# About FF Series

## Development Background

### Upgrade of industry and product

While the industrial upgrading in China requires high-quality, high-precision, and high-efficiency equipment, the end users demand products with higher quality, better appearance, and more reliability.

### Strong customer base

With the in-depth understanding of customer pain points and demand which based on tens of thousands of customers over time, we have set up a professional team to develop more cost-effective electric injection molding machines.

### Times call for domestically manufactured alternatives

While the Japanese products dominate the market at present, customers desire to have domestically manufactured alternatives to the imports for a more prompt comprehensive support and the best value for money.

### Automation and intellectualization are the trends

The growing demands for industrial automation and intellectualization ask for better products to increase customer value. Yizumi responds to this need with the new generation FF series electric injection molding machines.

## Core value Proposition

Yizumi is committed to developing a product that meets the technology and quality standards of Japanese electric injection molding machines, provides more cost-effective experiences, and better fulfills customers' expectations of return on investment.

### Upgrade from conventional models

Upgrading to a level that has higher requirements than conventional machines and allows customers to easily realize the automation and intellectualization while improving quality consistency and efficiency.

### Upgrade to meet application requirements

Compared to conventional models, the new electric series of injection molding machines enhances the performance in all aspects to meet the optimized requirements (e.g. Thickness, precision, and complexity) of more stringent core elements of products.

## Critical Success Factors

### Warranted by the overall strength of Yizumi

Yizumi has the powerful capacity in HW/SW development, competent R&D teams, and rigorous quality control system.

### Advanced integrated project development (IPD) process assurance



The rigorous and comprehensive IPD process established based on the in-depth understanding of customer needs and pain points ensures a high degree of customer satisfaction.

### In-depth industrial know-how and collaboration

With years of accumulated knowledge in machine designs, Yizumi is committed to creating the electric injection molding machines that meet our customer's product needs through collaboration with international top-level expert teams.

# FF Series Electric Injection Molding Machine

## Three Major Customer Value Propositions:

- 
**Stability & Precision**
- 
**Efficiency & energy saving**
- 
**Automation & Intellectualization**

Yizumi is committed to developing a product that meets the technology and quality standards of Japanese electric injection molding machines, provides more cost-effective experiences, and better fulfills customers' expectations of return on investment. Upgrading to a level that has higher requirements than conventional machines and allows customers to easily realize the automation and intellectualization while improving quality consistency and efficiency. Performance improvement in all aspects in comparison with conventional models to meet the optimized requirements (e.g. Thickness, precision, and complexity) of more stringent core elements of products.



※The data above are derived from Yizumi's lab results and are for your reference only;



## Three Major Customer Value Propositions

### Stability & Precision:

#### ► High stability of the Tie-Bar Free (TBF) technology

Contact-free tie bars allow fast and stable mold opening/closing and significantly reduce energy consumption, causing no pollution to the work environment

#### ► Highly stable three linear guider support (TLGS) technology

High precision linear guide supports significantly reduce the friction of the plasticizing unit and improves the pressure stability of plasticizing and injection, resulting in stable product quality. In the meantime, the linear guide effectively reduces energy consumption and enhances the smoothness of mold opening/closing

#### ► High-precision sensor technology

The use of the world's leading position sensors with 2 million CPR resolution delivers incredible stability in position and speed control

#### ► Fully automatic lubrication system

While the lubricating grease works as the blood of injection molding machine, the fully automatic maintenance-free lubrication system ensures the long-term operation stability of the machine

### Efficiency & Energy saving:

#### ► Double the injection speed

Compared with conventional machines, doubling the injection speed does more than shortening the injection time. It brings more possibilities to product design and allows customers to enjoy greater flexibility in terms of wall thickness, sprue size and precision of the molded parts

#### ► Energy-saving

Servo motors and high-efficiency transmission ensure good energy utilization of the equipment. Compared with ordinary injection molding machines, it can save energy by 30-50% (varies according to working conditions);

#### ► Increase mold opening and closing speed by 50%

Dry cycle has a great importance to customers as the faster dry cycle results in higher productivity

#### ► Multi-axis synchronization

As the mold opening/closing, injection, plasticizing, and ejection are driven by separate motors, the easy synchronization of processes reduces the cycle time of the production

#### ► Plasticizing speed is significantly increased

The increase in plasticizing speed reduces the cycle time while delivering enhanced production stability

### Automation & Intellectualization:

► Optimized automation interface for centralized control of integrated robot, hot runner, and auxiliary

► SMART mold protection to ensure the safe use of high-value molds in an unmanned operating environment

► The high stability and consistency of the machine process parameters allow unattended operation for an extended time

► Full data monitoring and extraction provide a solid foundation for intellectualization

► With accurate mold opening and full-featured second mold closing and opening, the automation of special process is fully warranted

► The intelligent sorting system automatically removes defect parts to ensure the production quality

► Combined with MEC, the intelligent Statistics Process Control (SPC) helps to achieve automation and informationization

► Smart Clamping Force Management (SCFM) system

► Smart Injection Control (SIC)

► Integrated factory management system with Yi CMS + Yi MES



#### High-rigid design of moving platen

Provide good rigidity and uniform force distribution with platen parallelism  $\leq 0.03\text{mm}$ , suitable for injection molding with precision molds

#### ► Highly stable clamping unit

Fast and steady mold opening/closing speed. Repeatability of mold opening/closing positions  $\pm 0.03\text{mm}$

#### European KEBA2000 controller

The powerful system is easy to operate and ideal for the high-performance solutions for electric injection molding machines

#### Excellent injection stability

More accurate control for more stable and reliable molding precision. The stability precision of injection pressure and holding pressure is at  $\pm 0.1\text{Mpa}$

# Clamping Unit

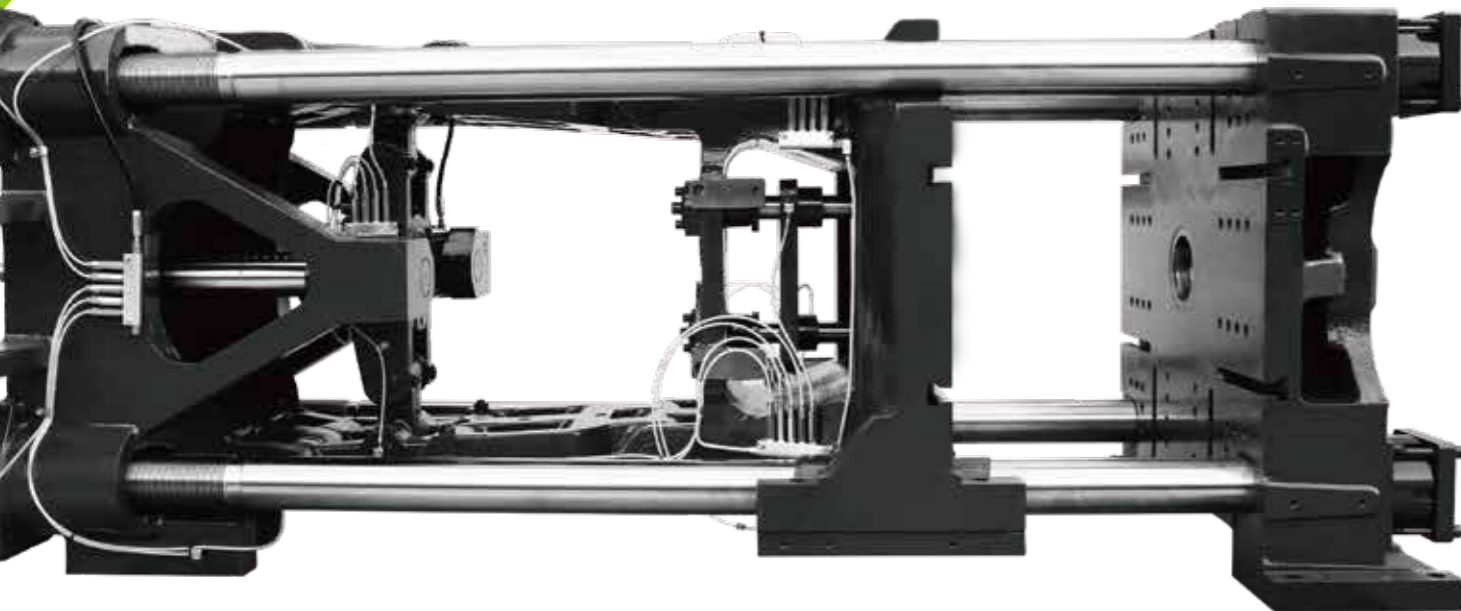

## High-rigid design of moving platen

- ▶ Offer great rigidity and uniform distribution of force
- ▶ Suitable for injection molding with precision molds
- ▶ High repeatability of mold-open end position
- ▶ Platen parallelism (with load)  $\leq 0.05\text{mm}$  (FF90-240)
- ▶ Platen parallelism (with load)  $\leq 0.08\text{mm}$  (FF300-400)
- ▶ Faster dry cycle



## Dual-cylinder parallel ejection design

- ▶ Uniform force application for mold release
- ▶ Servo motor driven ejection is optional
- ▶ Can achieve functions such as various modes of synchronized ejection and ejector retraction, gate cutting inside the mold, etc.
- ▶ Accuracy of ejection position up to **0.2mm**, conducive to product accuracy and repeatability.

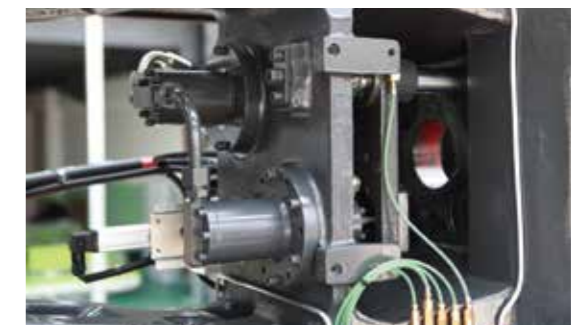

## High stability of the TBF technology

- ▶ The clamping unit adopts the TBF (Tie Bar Free) technology for easy operation and maintenance
- ▶ Keep the mold area clean to prevent product contamination



## Linear rail moving design for mold opening/closing

- ▶ The directional accuracy reaches **0.02mm**
- ▶ Fast and steady mold opening/closing speed. Repeatability of mold opening/closing positions  $\pm 0.03\text{mm}$



## Unique “SMART” mold protection feature

- ▶ Can detect very small obstacles and resistance
- ▶ Reduce the extent of mold damage when there are foreign objects in the mold cavity or faulty operation occurs

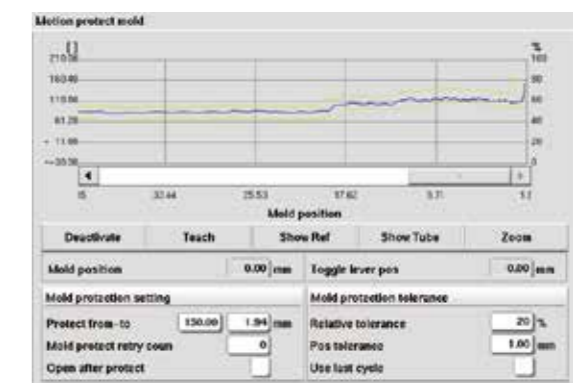



# Injection Unit

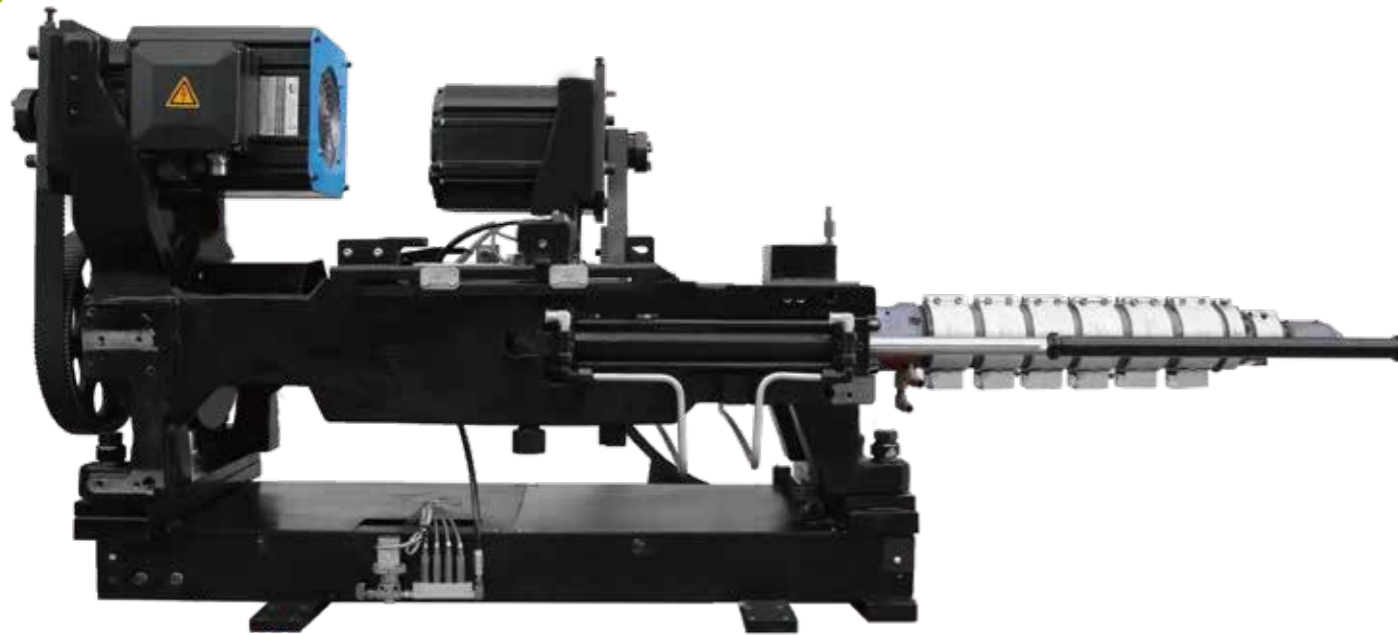

## The use of advanced LGS (Linear Guide Support) technology

- ▶ Integrated design enhances the overall rigidity of the injection unit
- ▶ No unnecessary friction. Fast forward and backward



Close-up



## Dedicated screws for different materials

- ▶ DIN standards for barrel unit size, processing accuracy, surface finish, and material selection
- ▶ Increase the repeatability of injection



## Temperature closed loop control

- ▶ Static deviation:  $\pm 0.5^\circ$

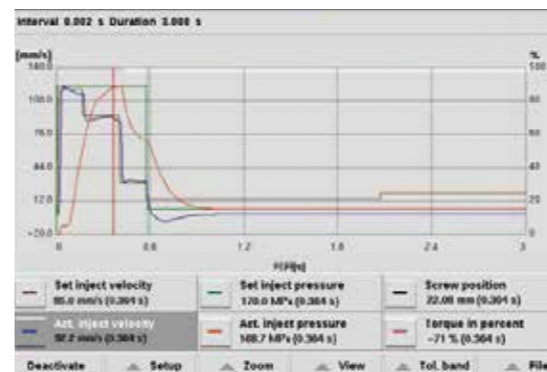

## Closed loop injection pressure control technology

- ▶ Provide more accurate control for more stable, reliable and precise molding.
- ▶ The stability precision of injection pressure and holding pressure is at  $\pm 0.1\text{Mpa}$

# Electrical Control System

## Using European KEBA2000 Controller

- ▶ The powerful system is easy to operate and ideal for the high-performance solutions for electric injection molding machines
- ▶ 12-inch/15-inch HD color touchscreen display with clear and neat screen layout
- ▶ Standard Process quality control (PDP), and Statistical process control (SPC) features
- ▶ Auto-sorting function
- ▶ Oscilloscope with chart display function to record the curve of process data change
- ▶ Centralized (networked) real-time remote operation and control
- ▶ The flexible I/O expansion modules allow integration of more features as needed and are programmable



Threaded design  
Stronger 3D effect

- ▶ Advanced HW and SW systems to support Industry 4.0
- ▶ 1ms scan cycle
- ▶ 16 levels of user access management to ensure data security

## Unique servo direct control (SDC) technology

- ▶ Process algorithm independently developed by Yizumi for the servo drive
- ▶ Four servo motors control injection, plasticizing, clamping, and ejection independently, allowing faster feedback, more responsive control, and improved control accuracy
- ▶ More precise control of speed, position and pressure to meet the requirements of precision equipment

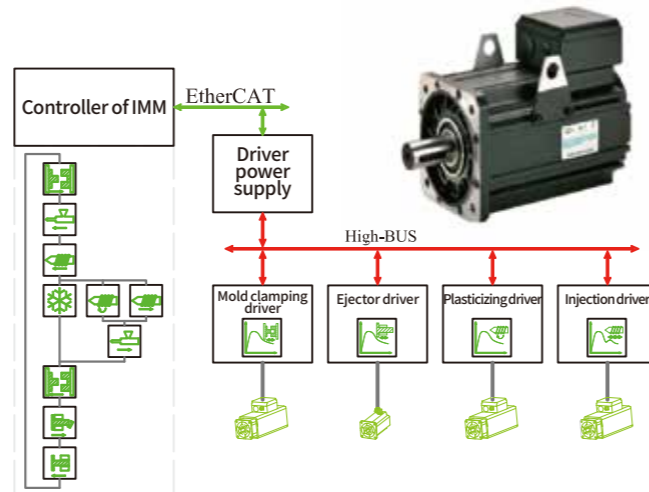

## All-metal baseboard for the electric control unit

- ▶ Galvanized mounting plate for better cooling and anti-interference capacity

## Standardized wiring layout

- ▶ Neat wiring and standardized interface layout for easy operation

# Modular Injection Unit Selections

The modular injection unit allows flexible combination with a number of options to quickly meet various application needs:

- ▶ 90T~1380T clamping force, 13 clamping modes
- ▶ Each clamping mode has the option to select different injection units and 9 types of barrel units
- ▶ 13 injection unit configurations, screws range  $\Phi 22 \sim \Phi 116 \text{mm}$
- ▶ Cover injection speeds of 160/200/300/350 (mm/s)

Machine \ Injection unit Screw	IU170	IU200	IU320	IU430	IU670	IU930	IU1350	IU1930	IU2700	IU3700	IU4800	IU6800	IU9000
FF90	22,26,30	26,30,35											
FF120		26,30,35	30,35,40	35,40,43									
FF160			30,35,40	35,40,43	40,48,53								
FF200				35,40,43	40,48,53	48,53,60							
FF240					40,48,53	48,53,60	53,60,68						
FF300						48,53,60	53,60,68	60,68,76					
FF380							53,60,68	60,68,76	68,76,84				
FF460								60,68,76	68,76,84	76,84,92			
FF550							53,60,68	60,68,76	68,76,84	76,84,92			
FF650								60,68,76	68,76,84	76,84,92	84,92,100		
FF850									68,76,84	76,84,92	84,92,100	92,100,108	
FF1080										76,84,92	84,92,100	92,100,108	100,108,116
FF1380											76,84,92	84,92,100	92,100,108



3C products



Automotive parts



Medical consumables



Home appliances

# FF90

## FF90 Machine Dimensions

CLAMPING UNIT						
Clamping force	kN	900				
Mold opening/closing stroke	mm	320				
Space between tie bars	mm	420×420				
Mold thickness	mm	150-410				
Ejector stroke	mm	80				
Ejector force	kN	22.6				
Number of ejectors		5				
INJECTION UNIT						
Model of injection unit		IU170 / IU170h			IU200 / IU200h	
International specification		165			198	
		A	B	C	A	B
Screw diameter	mm	22	26	30	26	30
Screw L/D ratio		22	22	22	22	20
Screw stroke	mm	115			140	
Stroke-bore ratio		5.23	4.42	3.83	5.4	4.7
Shot volume	cm <sup>3</sup>	44	61	81	74	99
Shot weight (PS)	g	40	56	75	68	91
Injection pressure	MPa	377	270	203	266	147
Holding pressure	MPa	302	216	162	213	118
Injection speed (Std./Opt.)	mm/s	200/350			200/350	
Injection rate	cm <sup>3</sup> /s	70	98	130	98	177
Screw speed	rpm	400			400	
Nozzle contact force	kN	20			20	
Heating power	kW	4.9	5.9	7.5	5.9	7.9
Total power	kW	35.5/36.7			35.5/37.9	
Total current	A	59.9/61.9			60/64	
GENERAL UNIT						
Oil pump motor	kW	10				
Max. system pressure	Mpa	16				
System flow	L/min	50				
Oil tank capacity	L	106				
Machine weight	kg	4030			4040	

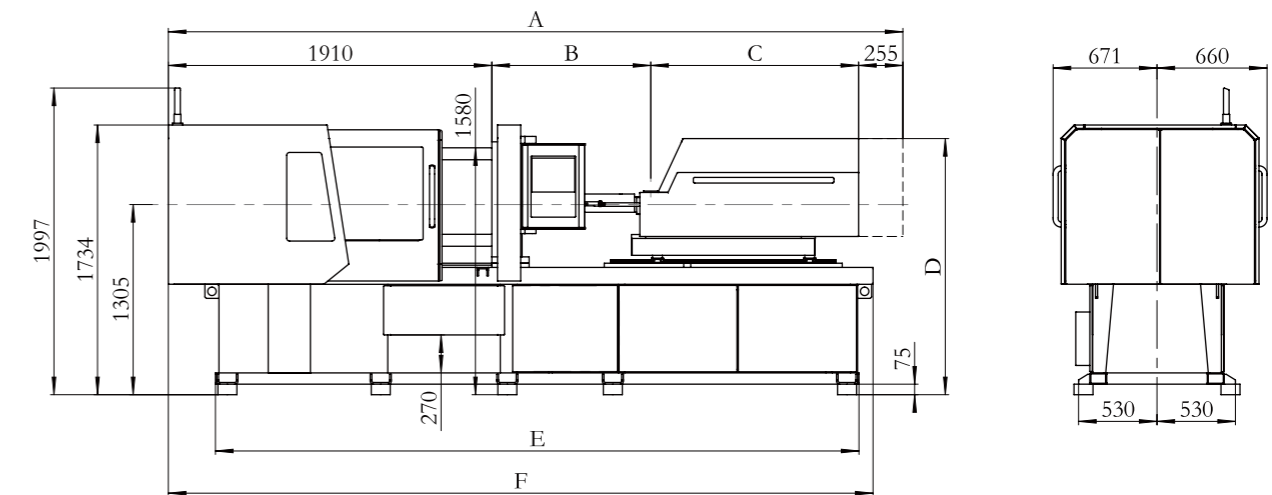

Model	A(A/B/C Screw)	B(A/B/C Screw)	C	D	E	F
IU170	4053/4148/4254	626/721/827	1262	1772	4185	4580
IU200	4148/4254/4313	721/827/886				

## FF90 Platen Dimensions

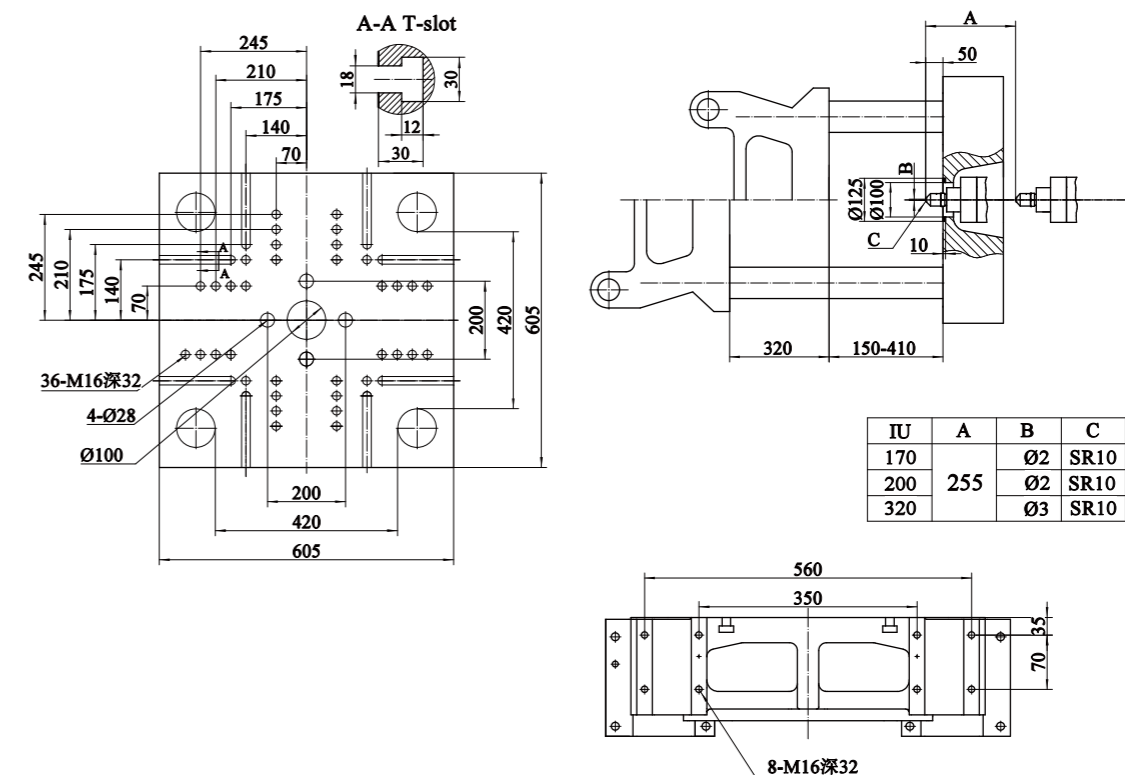

※The Data above were acquired by testing in the factory, only for your reference.



# FF120

CLAMPING UNIT										
Clamping force	kN	1200								
Mold opening/closing stroke	mm	370								
Space between tie bars	mm	480×480								
Mold thickness	mm	150-480								
Ejector stroke	mm	100								
Ejector force	kN	40								
Number of ejectors		5								
INJECTION UNIT										
Model of injection unit		IU200 / IU200h			IU320 / IU320h			IU430 / IU430h		
International specification		198			318			428		
		A	B	C	A	B	C	A	B	C
Screw diameter	mm	26	30	35	30	35	40	35	40	43
Screw L/D ratio		22	22	20	24	20	20	24	20	20
Screw stroke	mm	140			165			170		
Stroke-bore ratio		5.4	4.7	4.0	5.5	4.7	4.1	4.9	4.3	4.0
Shot volume	cm <sup>3</sup>	74	99	135	117	159	207	164	214	247
Shot weight (PS)	g	68	91	124	107	146	191	150	197	227
Injection pressure	MPa	266	200	147	272	200	153	261	200	173
Holding pressure	MPa	213	160	118	218	160	123	209	160	138
Injection speed (Std./Opt.)	mm/s	200/350			200/350			200/300		
Injection rate	cm <sup>3</sup> /s	98	130	177	130	177	231	177	231	267
Screw speed	rpm	400			400			400		
Nozzle contact force	kN	20			30			40		
Heating power	kW	5.9	7.5	7.9	7.3		7.9	8.9		
Total power	kW	35.5/37.9			36.4/52.4			48/56.9		
Total current	A	60/64			61.4/88.4			81/96		
GENERAL UNIT										
Oil pump motor	kW	10								
Max. system pressure	Mpa	16								
System flow	L/min	50								
Oil tank capacity	L	106								
Machine weight	kg	4800			4940			5400		

※The Data above were acquired by testing in the factory, only for your reference.

## FF120 Machine Dimensions

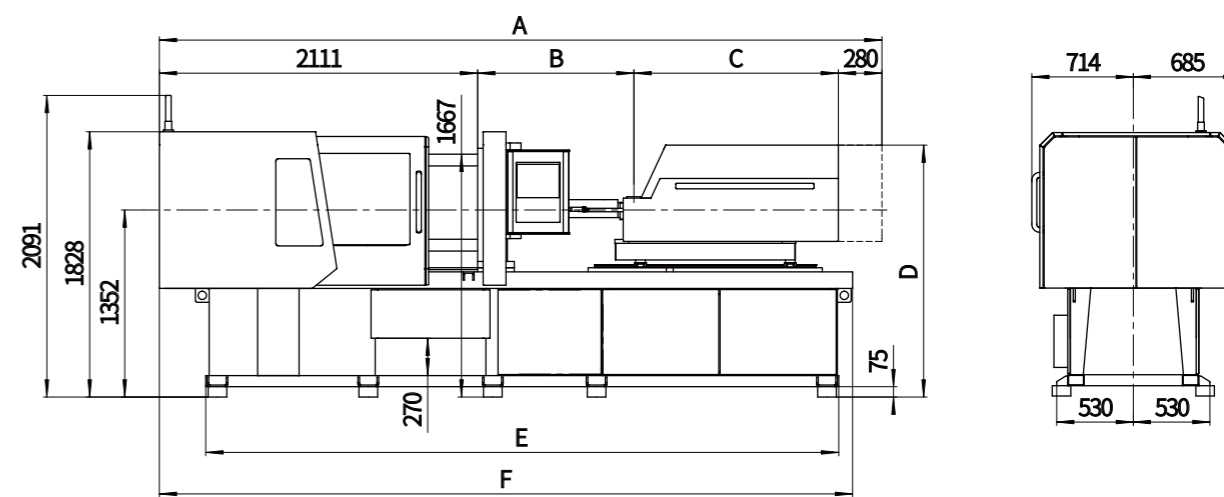

Model	A(A/B/C Screw)	B(A/B/C Screw)	C	D	E	F
IU200	4375/4481/4540	721/827/886	1263	1820	4386	4821
IU320	4735/4735/4810	866/866/941	1478	1822		
IU430	4853	1007	1455			

## FF120 Platen Dimensions

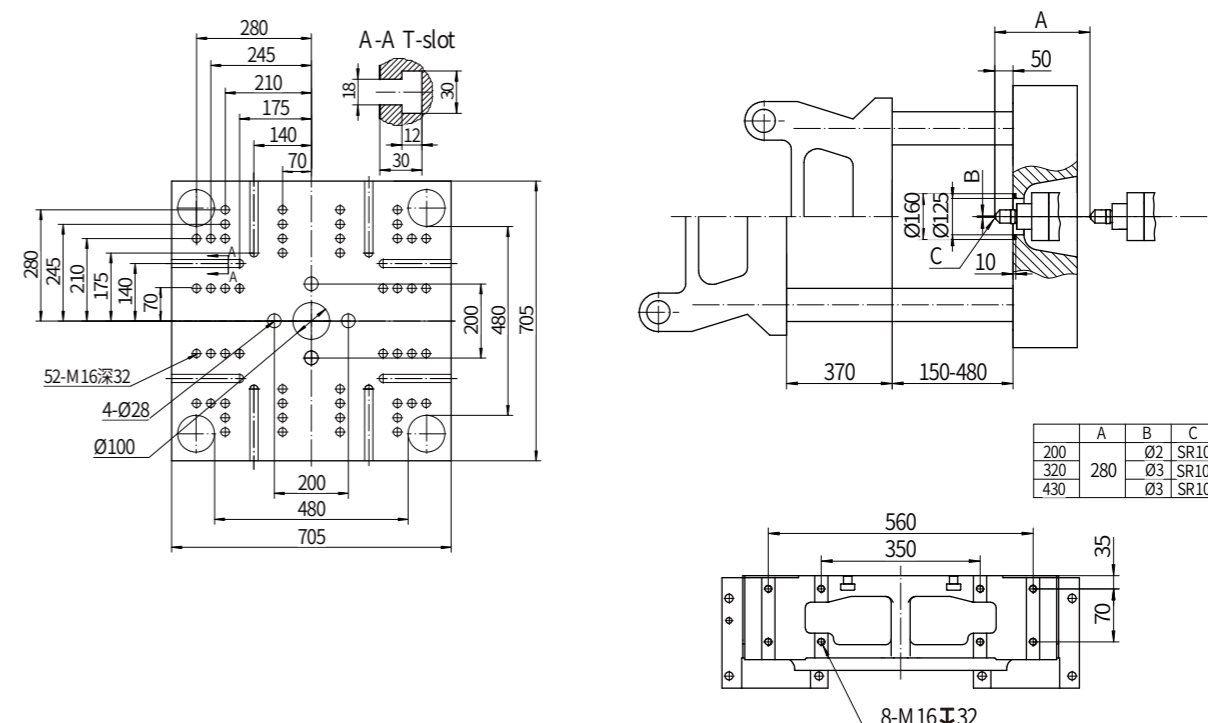

# FF160

CLAMPING UNIT										
Clamping force	kN	1600								
Mold opening/closing stroke	mm	430								
Space between tie bars	mm	530×530								
Mold thickness	mm	175-520								
Ejector stroke	mm	125								
Ejector force	kN	40								
Number of ejectors		5								
INJECTION UNIT										
Model of injection unit		IU320 / IU320h			IU430 / IU430h			IU670 / IU670h		
International specification		318			428			668		
		A	B	C	A	B	C	A	B	C
Screw diameter	mm	30	35	40	35	40	43	40	48	53
Screw L/D ratio		24	20	20	24	20	20	22.3	20	20
Screw stroke	mm	165			170			205		
Stroke-bore ratio		5.5	4.7	4.1	4.9	4.3	4.0	5.1	4.3	3.9
Shot volume	cm <sup>3</sup>	117	159	207	164	214	247	258	371	452
Shot weight (PS)	g	107	146	191	150	197	227	237	341	416
Injection pressure	MPa	272	200	153	261	200	173	259	180	148
Holding pressure	MPa	218	160	123	209	160	138	207	144	118
Injection speed (Std./Opt.)	mm/s	200/350			200/300			160/250		
Injection rate	cm <sup>3</sup> /s	130	177	231	177	231	267	185	266	325
Screw speed	rpm	400			400			350		
Nozzle contact force	kN	30			40			40		
Heating power	kW	7.3		7.9	8.9		10.6	10.9	12.1	
Total power	kW	36.4/52.4			48/56.9			55.1/61		
Total current	A	61.4/88.4			81/96			93/103		
GENERAL UNIT										
Oil pump motor	kW	10								
Max. system pressure	Mpa	16								
System flow	L/min	50								
Oil tank capacity	L	106								
Machine weight	kg	5850			6300			6380		

※The Data above were acquired by testing in the factory, only for your reference.

## FF160 Machine Dimensions

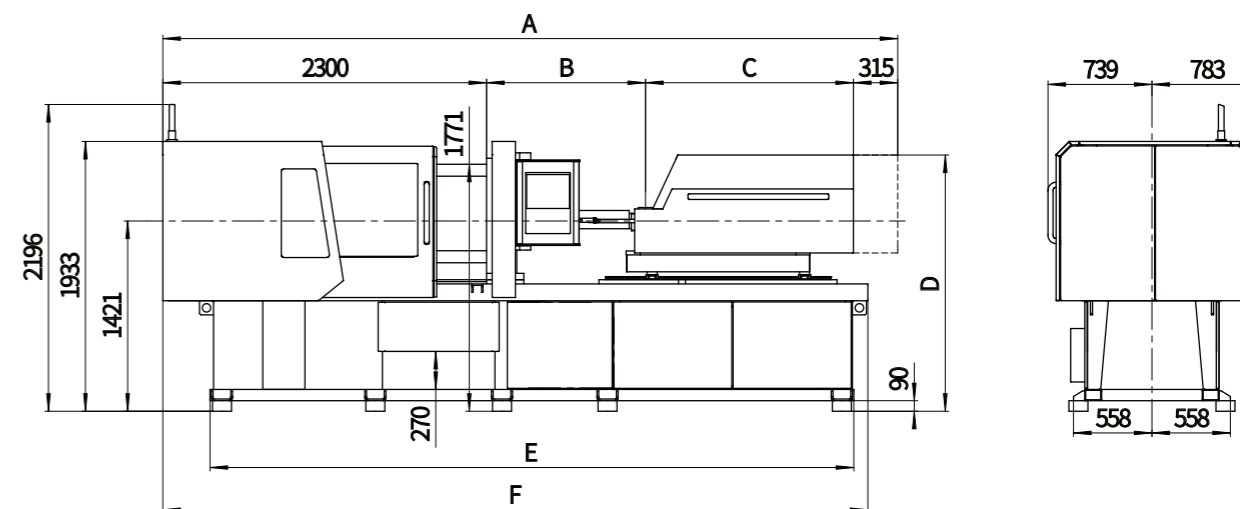

Model	A(A/B/C Screw)	B(A/B/C Screw)	C	D	E	F
IU320	4959/4959/5034	866/866/941	1478	1837	4575	5010
IU430	5077	1007	1455			
IU670	5414/5414/5514	1106/1106/1206	1693	1824	4945	5380

## FF160 Platen Dimensions

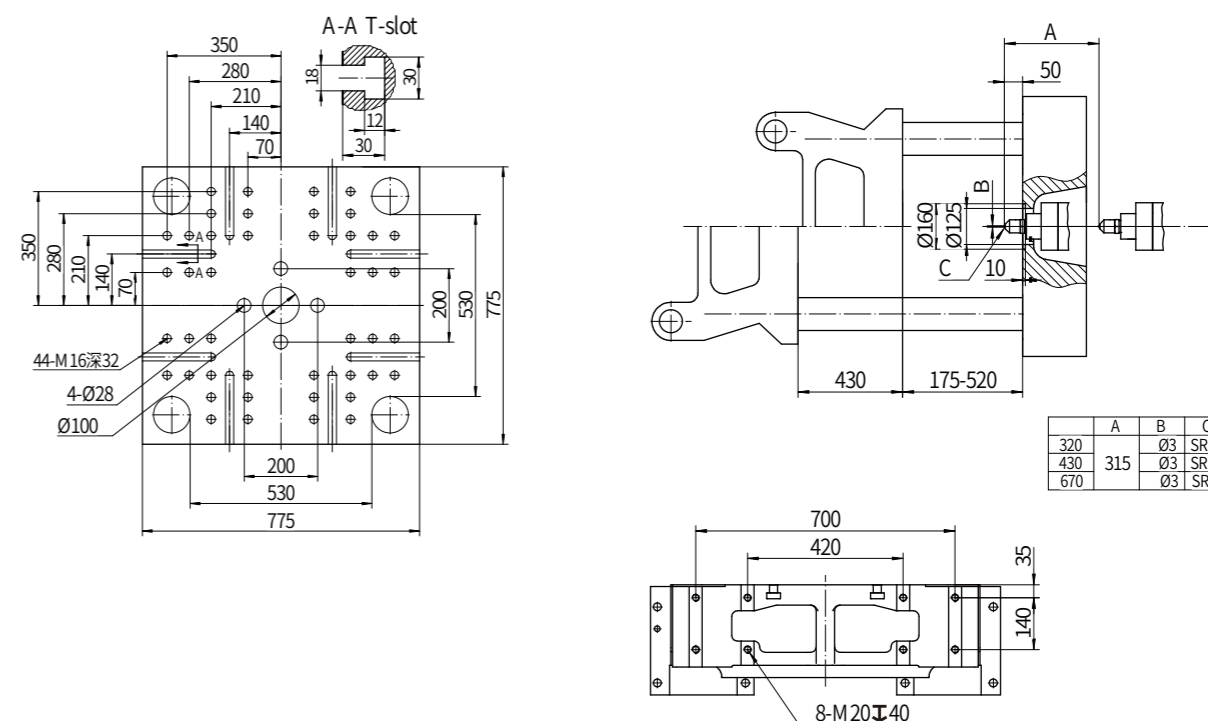

# FF200

## FF200 Machine Dimensions

CLAMPING UNIT										
Clamping force	kN	2000								
Mold opening/closing stroke	mm	480								
Space between tie bars	mm	580×580								
Mold thickness	mm	200-560								
Ejector stroke	mm	125								
Ejector force	kN	40								
Number of ejectors		9								
INJECTION UNIT										
Model of injection unit		IU430 / IU430h			IU670 / IU670h			IU930		
International specification		428			668			933		
		A	B	C	A	B	C	A	B	C
Screw diameter	mm	35	40	43	40	48	53	48	53	60
Screw L/D ratio		24	20	20	22.3	20	20	22	20	20
Screw stroke	mm	170			205			235		
Stroke-bore ratio		4.9	4.3	4.0	5.1	4.3	3.9	4.9	4.4	3.9
Shot volume	cm <sup>3</sup>	164	214	247	258	371	452	425	518	664
Shot weight (PS)	g	150	197	227	237	341	416	391	477	611
Injection pressure	MPa	261	200	173	259	180	148	219	180	140
Holding pressure	MPa	209	160	138	207	144	118	176	144	112
Injection speed (Std./Opt.)	mm/s	200/300			160/250			160		
Injection rate	cm <sup>3</sup> /s	177	231	267	185	266	325	266	325	416
Screw speed	rpm	400			350			320		
Nozzle contact force	kN	40			40			60		
Heating power	kW	8.9			10.6	10.9	12.1	13.6		16.7
Total power	kw	48/56.9			55.1/61			68.1		
Total current	A	81/96			93/103			114.9		
GENERAL UNIT										
Oil pump motor	kW	10								
Max. system pressure	Mpa	16								
System flow	L/min	50								
Oil tank capacity	L	106								
Machine weight	kg	6730			6810			7450		

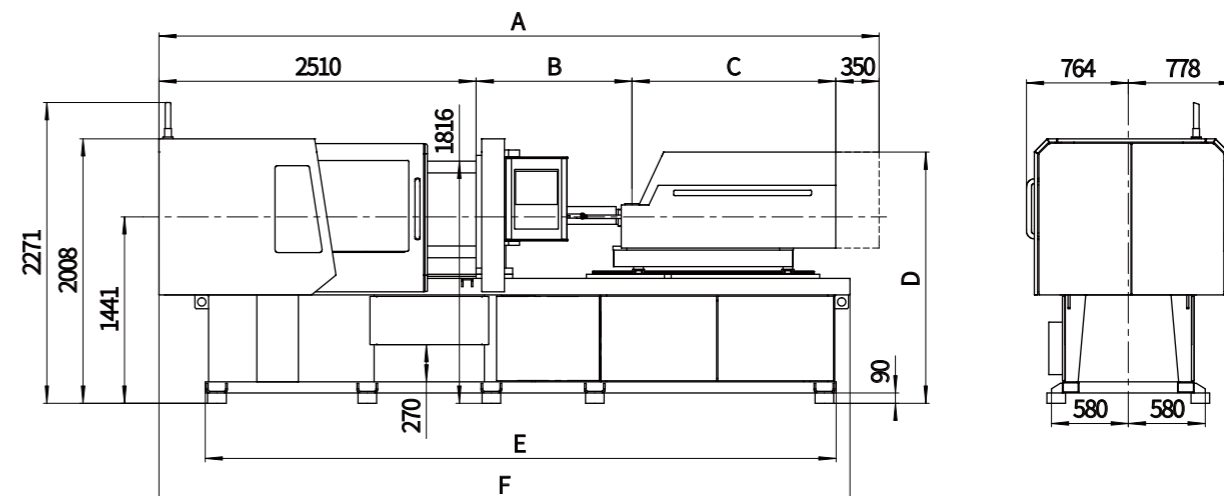

Model	A(A/B/C Screw)	B(A/B/C Screw)	C	D	E	F
IU430	5322	1007	1455	1837	5115	5550
IU670	5659/5659/5759	1106/1106/1206	1693	1907		
IU930	5949/5949/6093	1219/1219/1363	1870	2022	5415	5850

## FF200 Platen Dimensions

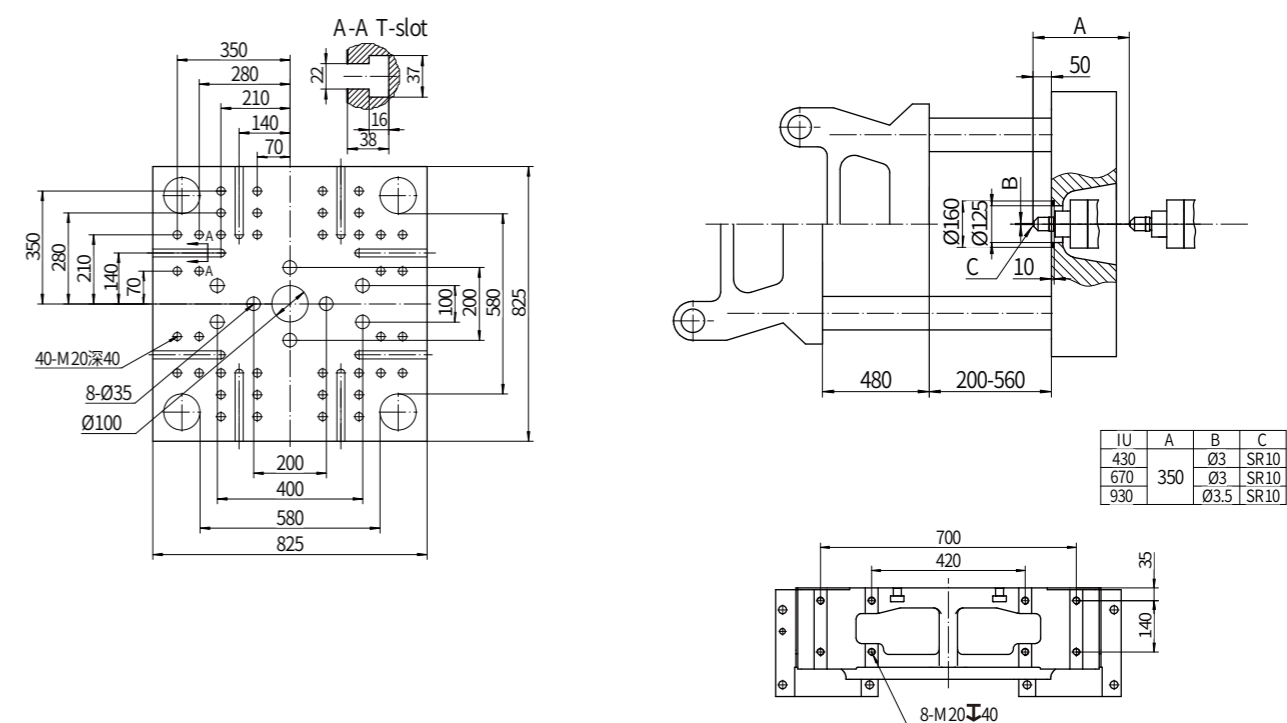

※The Data above were acquired by testing in the factory, only for your reference.



# FF240

## FF240 Machine Dimensions

CLAMPING UNIT										
Clamping force	kN	2400								
Mold opening/closing stroke	mm	530								
Space between tie bars	mm	630×630								
Mold thickness	mm	220-600								
Ejector stroke	mm	150								
Ejector force	kN	55.6								
Number of ejectors		13								
INJECTION UNIT										
Model of injection unit		IU670 / IU670h			IU930			IU1350		
International specification		668			933			1349		
		A	B	C	A	B	C	A	B	C
Screw diameter	mm	40	48	53	48	53	60	53	60	68
Screw L/D ratio		22.3	20	20	22	20	20	22.6	20	20
Screw stroke	mm	205			235			265		
Stroke-bore ratio		5.1	4.3	3.9	4.9	4.4	3.9	5.0	4.4	3.9
Shot volume	cm <sup>3</sup>	258	371	452	425	518	664	585	749	962
Shot weight (PS)	g	237	341	416	391	477	611	538	689	885
Injection pressure	MPa	259	180	148	219	180	140	231	180	140
Holding pressure	MPa	207	144	118	176	144	112	185	144	112
Injection speed (Std./Opt.)	mm/s	160/250			160			160		
Injection rate	cm <sup>3</sup> /s	185	266	325	266	325	416	325	416	535
Screw speed	rpm	350			320			300		
Nozzle contact force	kN	40			60			60		
Heating power	kW	10.6	10.9	12.1	13.6		16.7	16.4		18.8
Total power	kw	55.1/61			68.1			72.9		
Total current	A	93/103			114.9			123		
GENERAL UNIT										
Oil pump motor	kW	15								
Max. system pressure	Mpa	17.5								
System flow	L/min	64								
Oil tank capacity	L	106								
Machine weight	kg	9200			9840			10950		

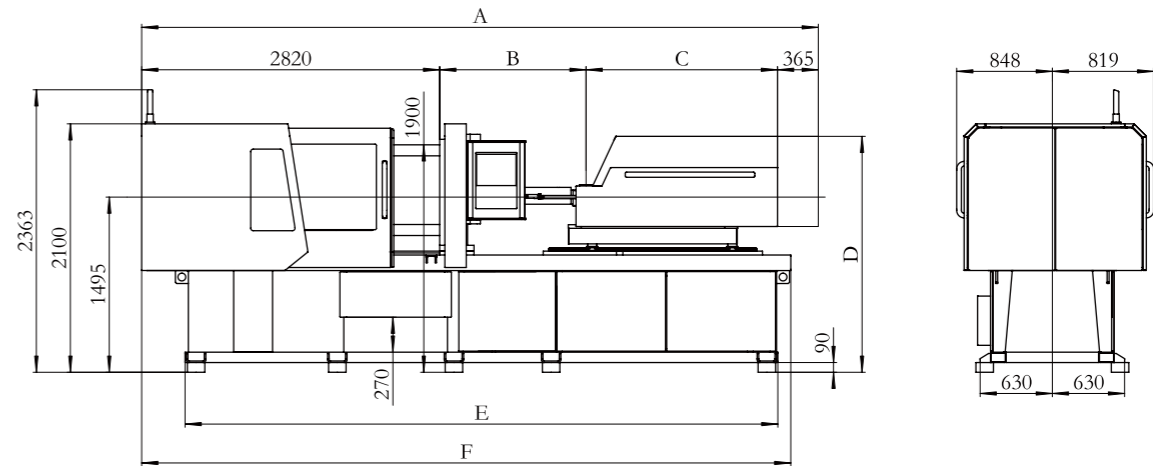

Model	A(A/B/C Screw)	B(A/B/C Screw)	C	D	E	F
IU670	5924/5984/6084	1146/1106/1206	1693	1962	5705	6190
IU930	6274/6274/6418	1219/1219/1363	1870	2075		
IU1350	6799/6799/6959	1391/1391/1551	2223	2110	6335	6820

## FF240 Platen Dimensions

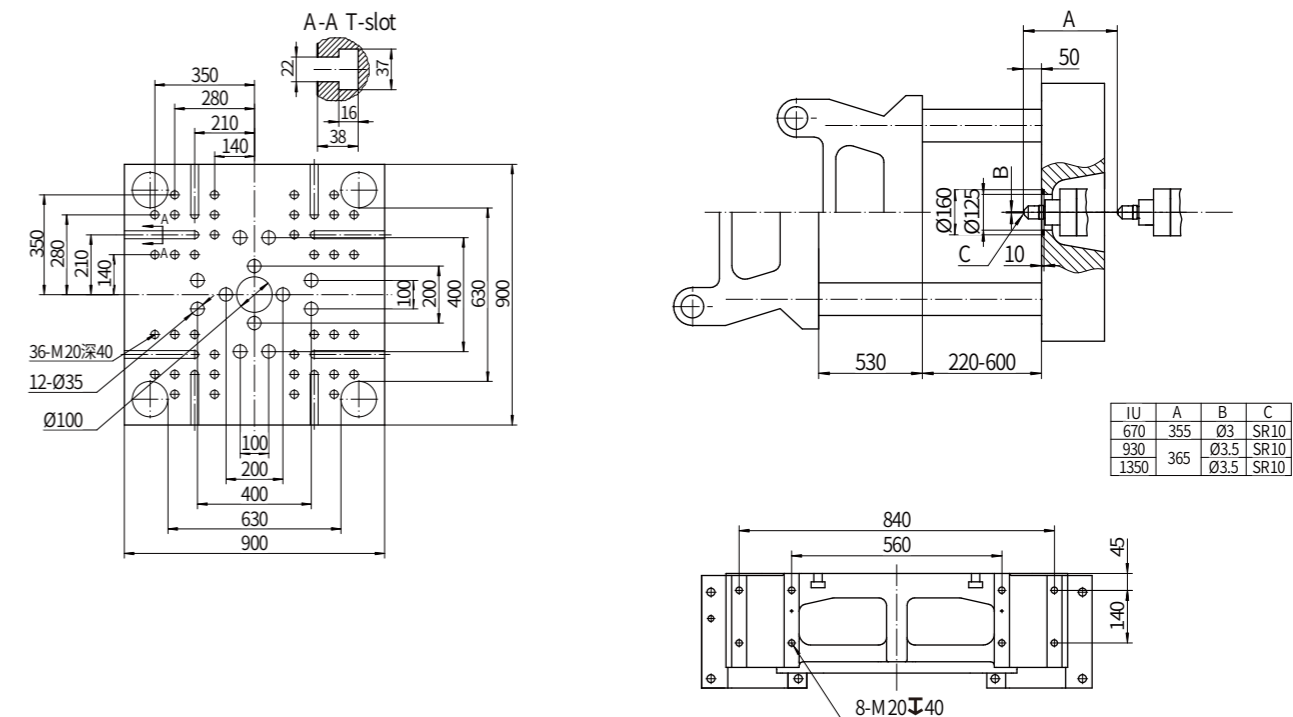

※The Data above were acquired by testing in the factory, only for your reference.

# FF300

## FF300 Machine Dimensions

CLAMPING UNIT										
Clamping force	kN	3000								
Mold opening/closing stroke	mm	610								
Space between tie bars	mm	720×720								
Mold thickness	mm	250-650								
Ejector stroke	mm	150								
Ejector force	kN	55.6								
Number of ejectors		13								
INJECTION UNIT										
Model of injection unit		IU930			IU1350			IU1930		
International specification		933			1349			1928		
		A	B	C	A	B	C	A	B	C
Screw diameter	mm	48	53	60	53	60	68	60	68	76
Screw L/D ratio		22	20	20	22.6	20	20	22.6	20	20
Screw stroke	mm	235			265			295		
Stroke-bore ratio		4.9	4.4	3.9	5.0	4.4	3.9	4.9	4.3	3.9
Shot volume	cm <sup>3</sup>	425	518	664	585	749	962	834	1071	1338
Shot weight (PS)	g	391	477	611	538	689	885	767	986	1231
Injection pressure	MPa	219	180	140	231	180	140	231	180	144
Holding pressure	MPa	176	144	112	185	144	112	185	144	115
Injection speed (Std./Opt.)	mm/s	160			160			160		
Injection rate	cm <sup>3</sup> /s	266	325	416	325	416	535	416	535	668
Screw speed	rpm	320			300			250		
Nozzle contact force	kN	60			60			60		
Heating power	kW	13.6		16.7	16.4		18.8	22.2		23.5
Total power	kw	68.1			72.9			126.2		
Total current	A	114.9			123			213		
GENERAL UNIT										
Oil pump motor	kW	15								
Max. system pressure	Mpa	17.5								
System flow	L/min	64								
Oil tank capacity	L	106								
Machine weight	kg	11370			12480			12900		

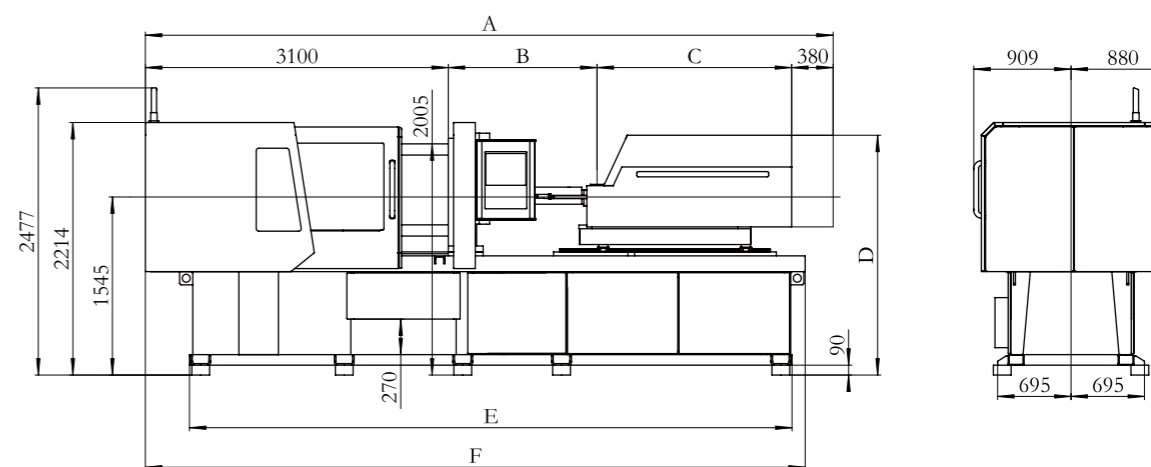

Model	A(A/B/C Screw)	B(A/B/C Screw)	C	D	E	F
IU930	6569/6569/6713	1219/1219/1363	1870	2125	6445	7010
IU1350	7094/7094/7254	1391/1391/1551	2223	2160	6445	7010
IU1930	7085/7085/7260	1565/1565/1740	2040	2270	6445	7010

## FF300 Platen Dimensions

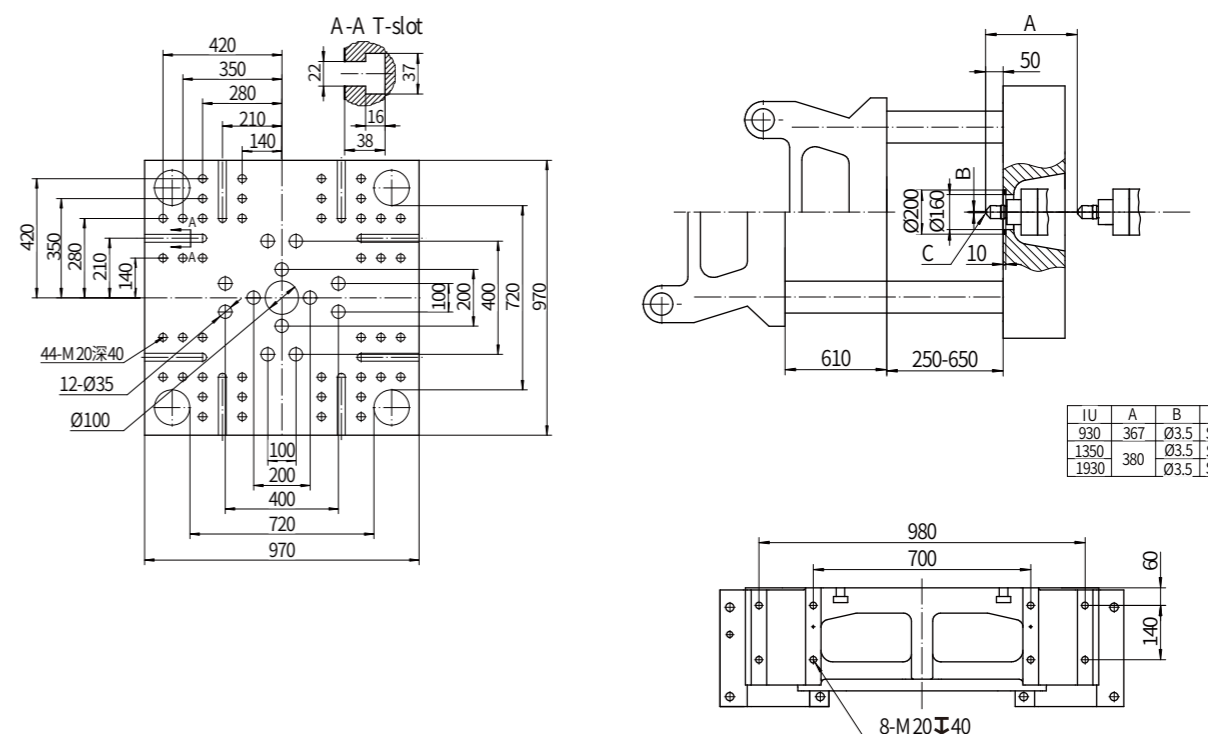

※The Data above were acquired by testing in the factory, only for your reference.

# FF380

## FF380 Machine Dimensions

CLAMPING UNIT										
Clamping force	kN	3800								
Mold opening/closing stroke	mm	710								
Space between tie bars	mm	820×820								
Mold thickness	mm	290-720								
Ejector stroke	mm	200								
Ejector force	kN	99								
Number of ejectors		13								
INJECTION UNIT										
Model of injection unit		IU1350			IU1930			IU2700		
International specification		1349			1928			2695		
		A	B	C	A	B	C	A	B	C
Screw diameter	mm	53	60	68	60	68	76	68	76	84
Screw L/D ratio		22.6	20	20	22.6	20	20	22.3	20	20
Screw stroke	mm	265			295			330		
Stroke-bore ratio		5.0	4.4	3.9	4.9	4.3	3.9	4.9	4.3	3.9
Shot volume	cm <sup>3</sup>	585	749	962	834	1071	1338	1198	1497	1829
Shot weight (PS)	g	538	689	885	767	986	1231	1103	1377	1682
Injection pressure	MPa	231	180	140	231	180	144	225	180	147
Holding pressure	MPa	185	144	112	185	144	115	180	144	118
Injection speed (Std./Opt.)	mm/s	160			160			160		
Injection rate	cm <sup>3</sup> /s	325	416	535	416	535	668	535	668	816
Screw speed	rpm	300			250			200		
Nozzle contact force	kN	60			60			100		
Heating power	kW	16.4		18.8	22.2		23.5	26.3		30.9
Total power	kW	72.9			126.2			133.9		
Total current	A	123			213			226		
GENERAL UNIT										
Oil pump motor	kW	25								
Max. system pressure	Mpa	17.5								
System flow	L/min	126								
Oil tank capacity	L	189								
Machine weight	kg	16880			17300			18690		

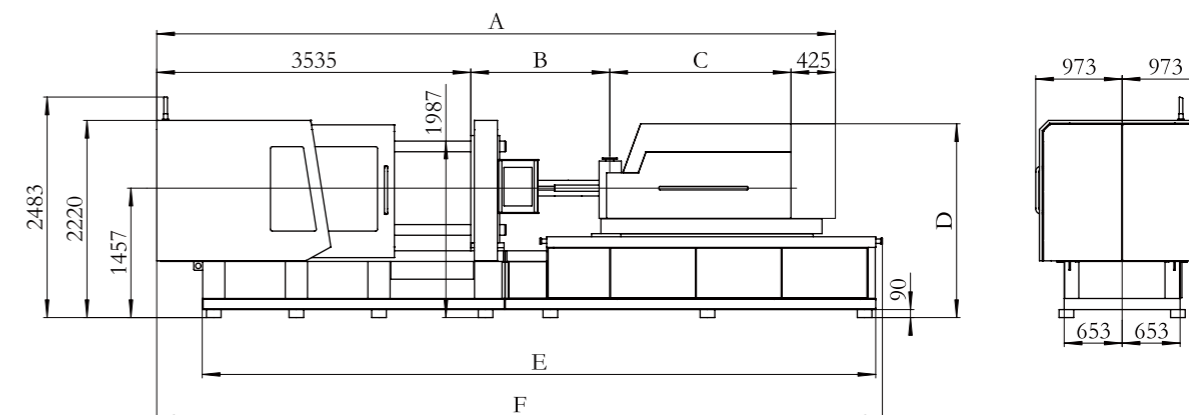

Model	A(A/B/C Screw)	B(A/B/C Screw)	C	D	E	F
IU1350	7574/7574/7734	1391/1391/1551	2223	2072	7582	8169
IU1930	7565/7565/7740	1565/1565/1740	2040	2182		
IU2700	8074/8074/8247	1769/1769/1942	2345			

## FF380 Platen Dimensions

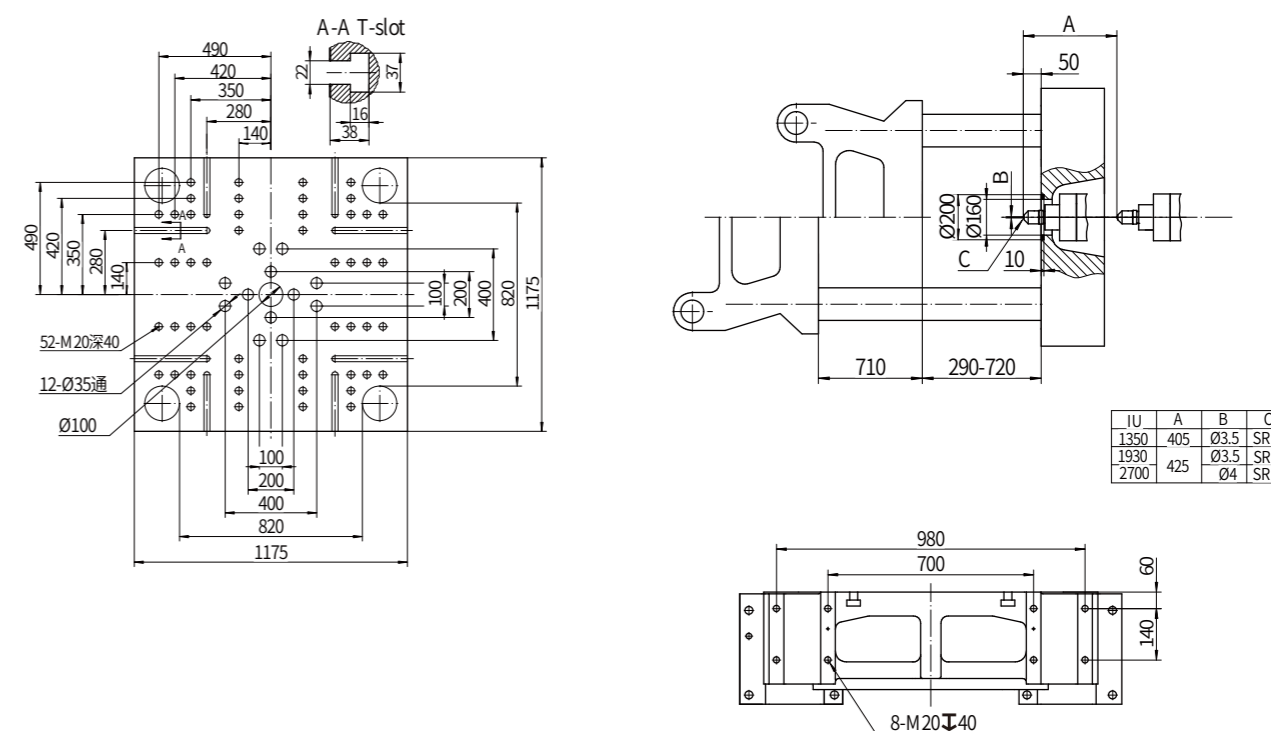

※The Data above were acquired by testing in the factory, only for your reference.



# FF460

CLAMPING UNIT										
Clamping force	kN	4600								
Mold opening/closing stroke	mm	810								
Space between tie bars	mm	920×920								
Mold thickness	mm	330-810								
Ejector stroke	mm	200								
Ejector force	kN	99								
Number of ejectors		17								
INJECTION UNIT										
Model of injection unit		IU1930			IU2700			IU3700		
International specification		1928			2695			3691		
		A	B	C	A	B	C	A	B	C
Screw diameter	mm	60	68	76	68	76	84	76	84	92
Screw L/D ratio		22.6	20	20	22.3	20	20	22.1	20	20
Screw stroke	mm	295			330			370		
Stroke-bore ratio		4.9	4.3	3.9	4.9	4.3	3.9	4.9	4.4	4.0
Shot volume	cm <sup>3</sup>	834	1071	1338	1198	1497	1829	1678	2050	2460
Shot weight (PS)	g	767	986	1231	1103	1377	1682	1544	1886	2263
Injection pressure	MPa	231	180	144	225	180	147	220	180	150
Holding pressure	MPa	185	144	115	180	144	118	176	144	120
Injection speed (Std./Opt.)	mm/s	160			160			160		
Injection rate	cm <sup>3</sup> /s	416	535	668	535	668	816	668	816	979
Screw speed	rpm	250			200			180		
Nozzle contact force	kN	60			100			100		
Heating power	kW	22.2		23.5	26.3		30.9	33.1		36.1
Total power	kW	126.2			133.9			153.4		
Total current	A	213			226			259		
GENERAL UNIT										
Oil pump motor	kW	25								
Max. system pressure	Mpa	17.5								
System flow	L/min	126								
Oil tank capacity	L	189								
Machine weight	kg	21460			22860			23150		

※The Data above were acquired by testing in the factory, only for your reference.

## FF460 Machine Dimensions

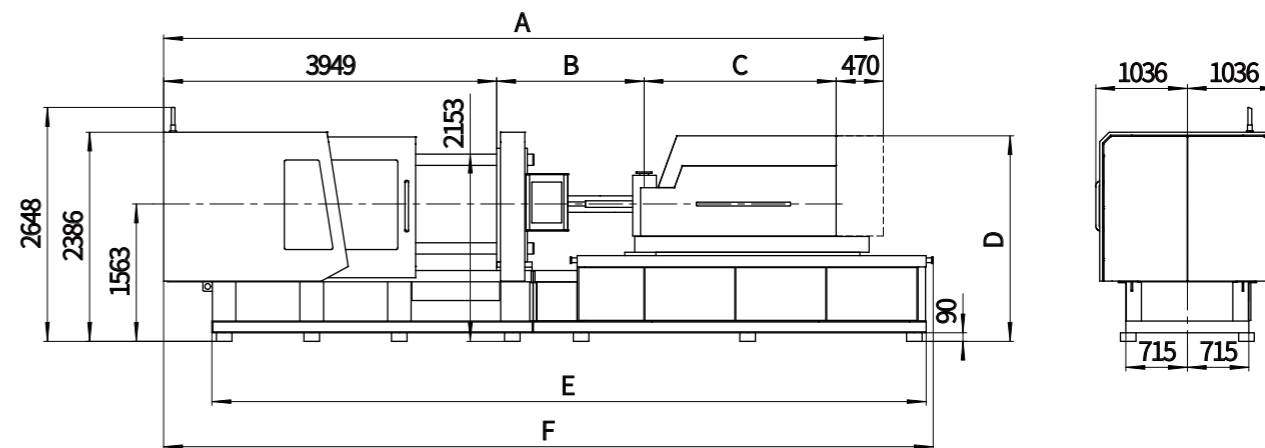

Model	A(A/B/C Screw)	B(A/B/C Screw)	C	D	E	F
IU1930	8024/8024/8199	1565/1565/1740	2040	2288	8041	8628
IU2700	8533/8533/8706	1769/1769/1942	2345			
IU3700	8837/8837/8997	1953/1953/2113	2465	2364	8221	8808

## FF460 Platen Dimensions

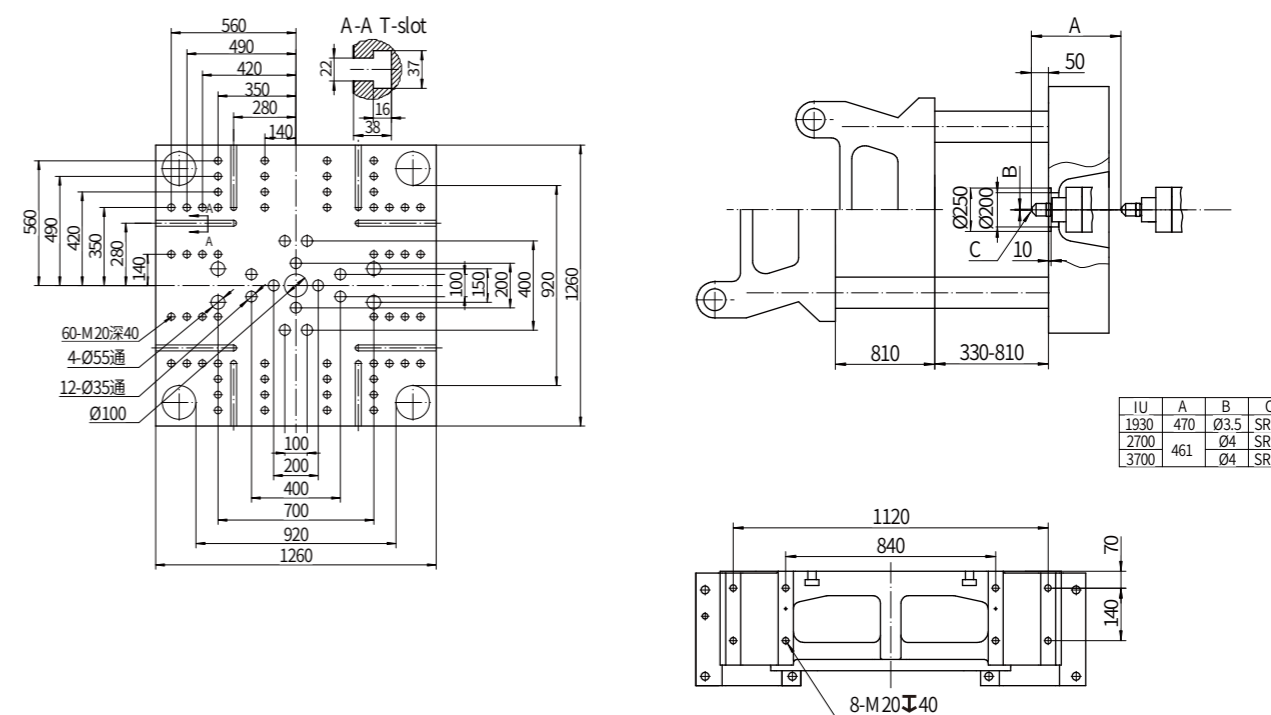

# FF550

## FF550 Machine Dimensions

CLAMPING UNIT													
Clamping force	kN	5500											
Mold opening/closing stroke	mm	900											
Space between tie bars	mm	970×970											
Mold thickness	mm	400-900											
Ejector stroke	mm	200											
Ejector force	kN	155											
Number of ejectors		23											
INJECTION UNIT													
Model of injection unit		IU1350			IU1930			IU2700			IU3700		
International specification		1349			1928			2695			3691		
		A	B	C	A	B	C	A	B	C	A	B	C
Screw diameter	mm	53	60	68	60	68	76	68	76	84	76	84	92
Screw L/D ratio		22.6	20	20	22.6	20	20	22.3	20	20	22.1	20	20
Screw stroke	mm	265			295			330			370		
Stroke-bore ratio		5.0	4.4	3.9	4.9	4.3	3.9	4.9	4.3	3.9	4.9	4.4	4.0
Shot volume	cm <sup>3</sup>	585	749	962	834	1071	1338	1198	1497	1829	1678	2050	2460
Shot weight (PS)	g	538	689	885	767	986	1231	1103	1377	1682	1544	1886	2263
Injection pressure	MPa	231	180	140	231	180	144	225	180	147	220	180	150
Holding pressure	MPa	185	144	112	185	144	115	180	144	118	176	144	120
Injection speed (Std./Opt.)	mm/s	160			160			160			160		
Injection rate	cm <sup>3</sup> /s	325	416	535	416	535	668	535	668	816	668	816	979
Screw speed	rpm	300			250			200			180		
Nozzle contact force	kN	60			60			100			100		
Heating power	kW	16.4	18.8		22.2	23.5		26.3	30.9		33.1	36.1	
Total power	kW	72.9			126.2			133.9			153.4		
Total current	A	123			213			226			259		
GENERAL UNIT													
Oil pump motor	kW	34											
Max. system pressure	Mpa	17.5											
System flow	L/min	168											
Oil tank capacity	L	190											

※The Data above were acquired by testing in the factory, only for your reference.

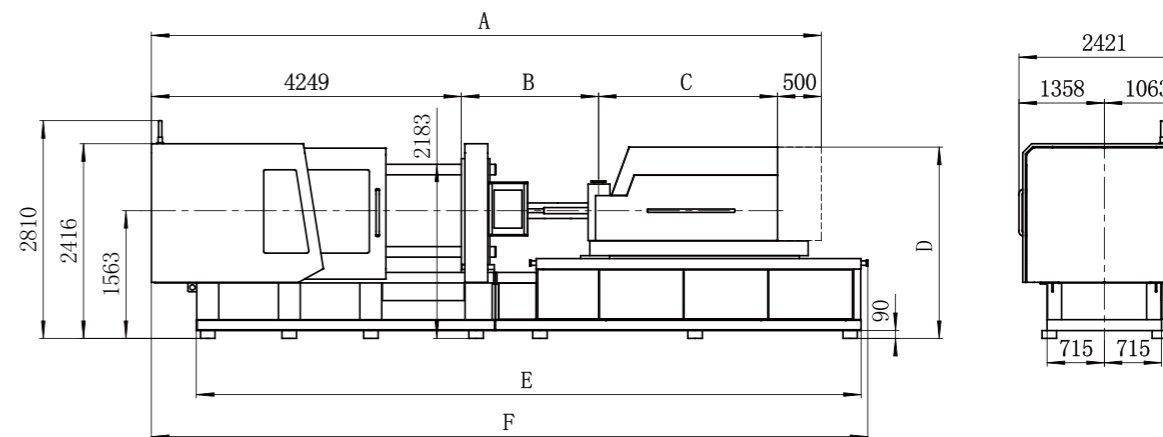

Model	A(A/B/C Screw)	B(A/B/C Screw)	C	D	E	F
IU1350	7975/7975/8095	1391/1391/1511	1835	2178	8203	8715
IU1930	8354/8354/8529	1565/1565/1740	2040	2288	8203	8715
IU2700	8864/8864/9037	1769/1769/1942	2345			
IU3700	9167/9167/9327	1953/1953/2113	2465	2364	8671	9183

## FF550 Platen Dimensions

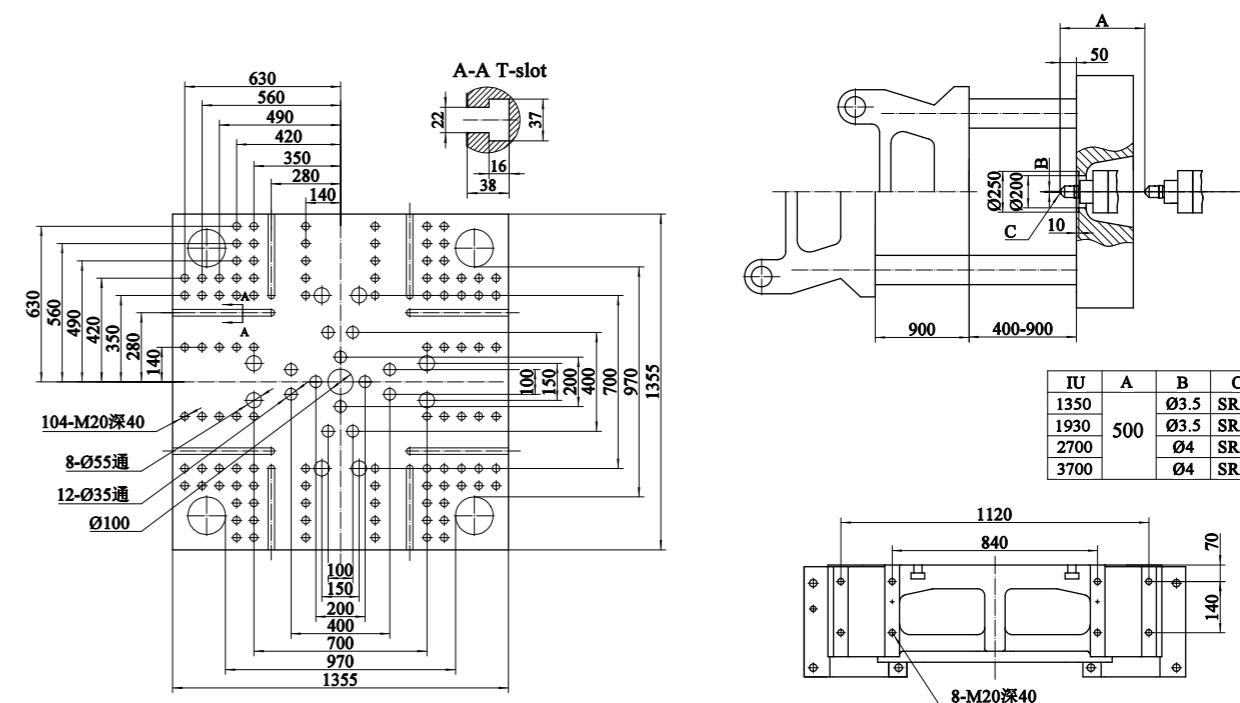

# FF650

CLAMPING UNIT													
Clamping force	kN	6500											
Mold opening/closing stroke	mm	1000											
Space between tie bars	mm	1080×1080											
Mold thickness	mm	420-1000											
Ejector stroke	mm	210											
Ejector force	kN	220											
Number of ejectors		23											
INJECTION UNIT													
Model of injection unit		IU1930			IU2700			IU3700			IU4800		
International specification		1928			2695			3691			4800		
		A	B	C	A	B	C	A	B	C	A	B	C
Screw diameter	mm	60	68	76	68	76	84	76	84	92	84	92	100
Screw L/D ratio		22.6	20	20	22.3	20	20	22.1	20	20	21.9	22	21.6
Screw stroke	mm	295			330			370			400		
Stroke-bore ratio		4.9	4.3	3.9	4.9	4.3	3.9	4.9	4.4	4.0	4.8	4.3	4.0
Shot volume	cm <sup>3</sup>	834	1071	1338	1198	1497	1829	1678	2050	2460	2217	2659	3142
Shot weight (PS)	g	767	986	1231	1103	1377	1682	1544	1886	2263	2039	2446	2890
Injection pressure	MPa	231	180	144	225	180	147	220	180	150	216	180	152
Holding pressure	MPa	185	144	115	180	144	118	176	144	120	173	144	122
Injection speed (Std./Opt.)	mm/s	160			160			160			160		
Injection rate	cm <sup>3</sup> /s	416	535	668	535	668	816	668	816	979	816	979	1156
Screw speed	rpm	250			200			180			150		
Nozzle contact force	kN	60			100			100			100		
Heating power	kW	22.2	23.5		26.3	30.9		33.1	36.1		37.5	41.2	45.0
Total power	kW	126.2			133.9			153.4			155.6		
Total current	A	213			226			259			262.7		
GENERAL UNIT													
Oil pump motor	kW	51											
Max. system pressure	Mpa	17.5											
System flow	L/min	263											
Oil tank capacity	L	300											

※ The Data above were acquired by testing in the factory, only for your reference.

## FF650 Machine Dimensions

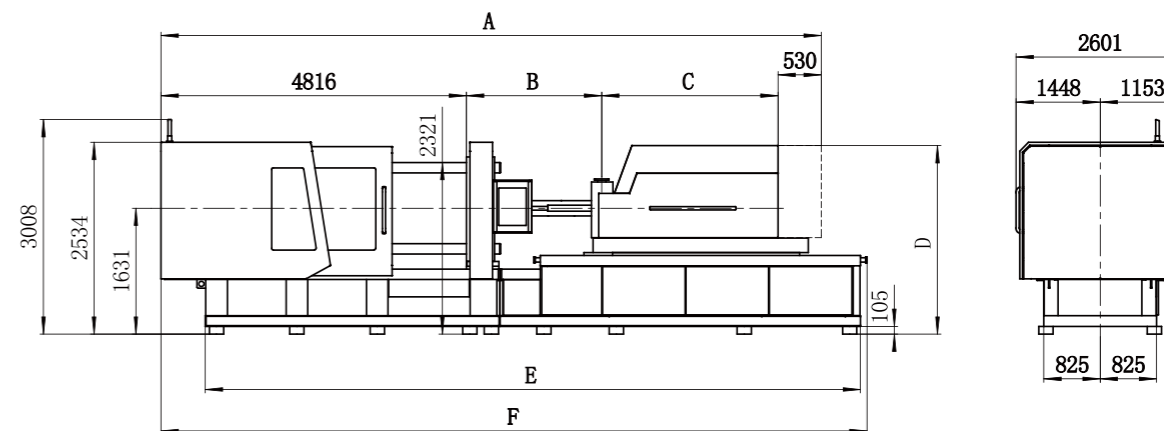

Model	A(A/B/C Screw)	B(A/B/C Screw)	C	D	E	F
IU1930	8951/8951/9126	1565/1565/1740	2040	2356	9143	9785
IU2700	9488/9488/9661	1769/1769/1942	2373			
IU3700	9764/9764/9924	1953/1953/2113	2465	2432	9743	10385
IU4800	10219/10414/10569	2149/2344/2499	2724	2485		

## FF650 Platen Dimensions

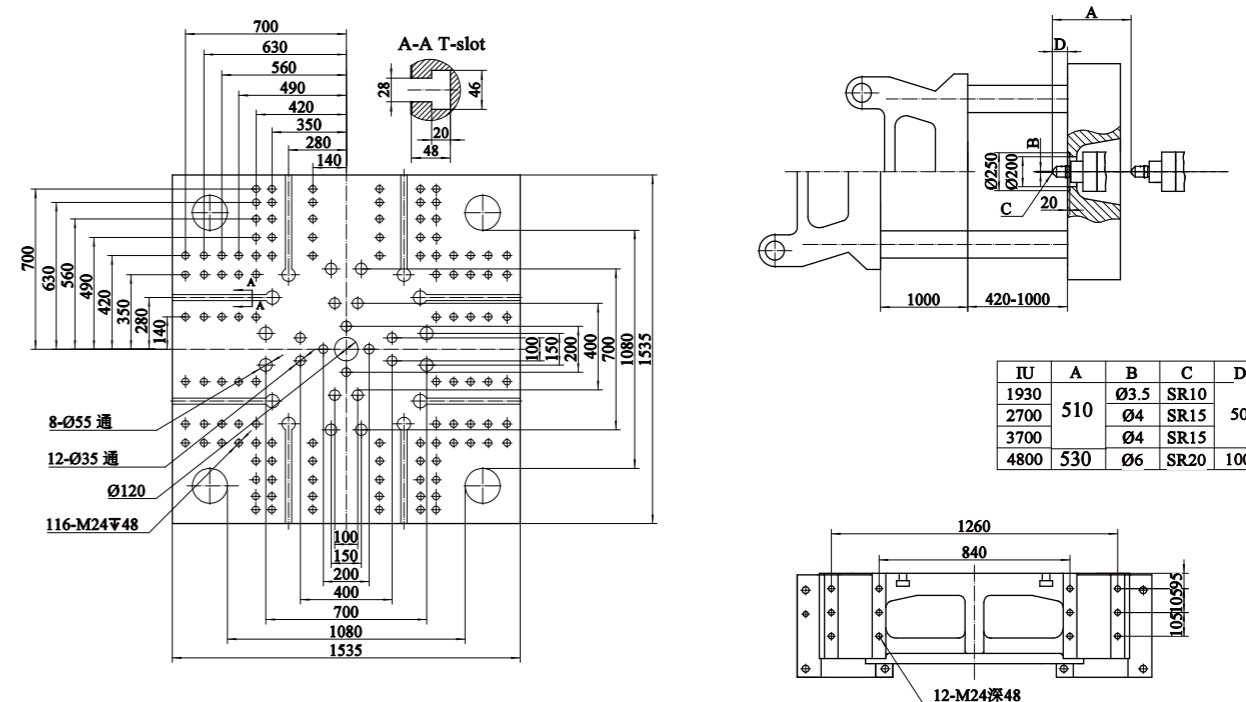



# FF850

CLAMPING UNIT													
Clamping force	kN	8500											
Mold opening/closing stroke	mm	1200											
Space between tie bars	mm	1120×1120											
Mold thickness	mm	500-1100											
Ejector stroke	mm	210											
Ejector force	kN	230											
Number of ejectors		23											
INJECTION UNIT													
Model of injection unit		IU2700			IU3700			IU4800			IU6800		
International specification		2695			3691			4800			6800		
		A	B	C	A	B	C	A	B	C	A	B	C
Screw diameter	mm	68	76	84	76	84	92	84	92	100	92	100	108
Screw L/D ratio		22.3	20	20	22.1	20	20	21.9	22	21.6	21.7	22	21.5
Screw stroke	mm	330			370			400			480		
Stroke-bore ratio		4.9	4.3	3.9	4.9	4.4	4.0	4.8	4.3	4.0	5.2	4.8	4.4
Shot volume	cm <sup>3</sup>	1198	1497	1829	1678	2050	2460	2217	2659	3142	3191	3770	4397
Shot weight (PS)	g	1103	1377	1682	1544	1886	2263	2039	2446	2890	2936	3468	4045
Injection pressure	MPa	225	180	147	220	180	150	216	180	152	213	180	154
Holding pressure	MPa	180	144	118	176	144	120	173	144	122	170	144	123
	mm/s	160			160			160			160		
Injection rate	cm <sup>3</sup> /s	581	726	887	726	887	1064	887	1064	1257	1064	1257	1466
Screw speed	rpm	200			180			150			150		
Nozzle contact force	kN	100			100			100			120		
Heating power	kW	26.3	30.9		33.1	36.1		36.5	41.2	45.0	41.7	47.2	54.1
Total power	kW	116.1			133.3			133.2			168.5		
Total current	A	226			259.0			262.7			361.6		
GENERAL UNIT													
Oil pump motor	kW	51											
Max. system pressure	Mpa	17.5											
System flow	L/min	263											
Oil tank capacity	L	300											

※ The Data above were acquired by testing in the factory, only for your reference.

## FF850 Machine Dimensions

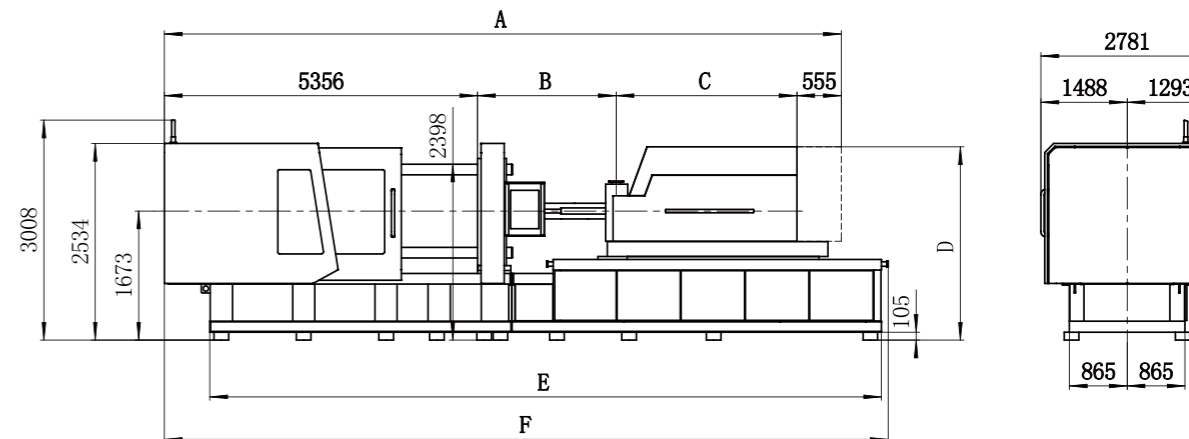

Model	A(A/B/C Screw)	B(A/B/C Screw)	C	D	E	F
IU2700	10053/10053/10226	1769/1769/1942	2373	2398	10008	10680
IU3700	10329/10329/10489	1953/1953/2113	2465	2474		
IU4800	10784/10979/11134	2149/2344/2499	2724	2527		
IU6800	11267/11487/11617.5	2319/2539/2669.5	3037	2532	210608	11280

## FF850 Platen Dimensions

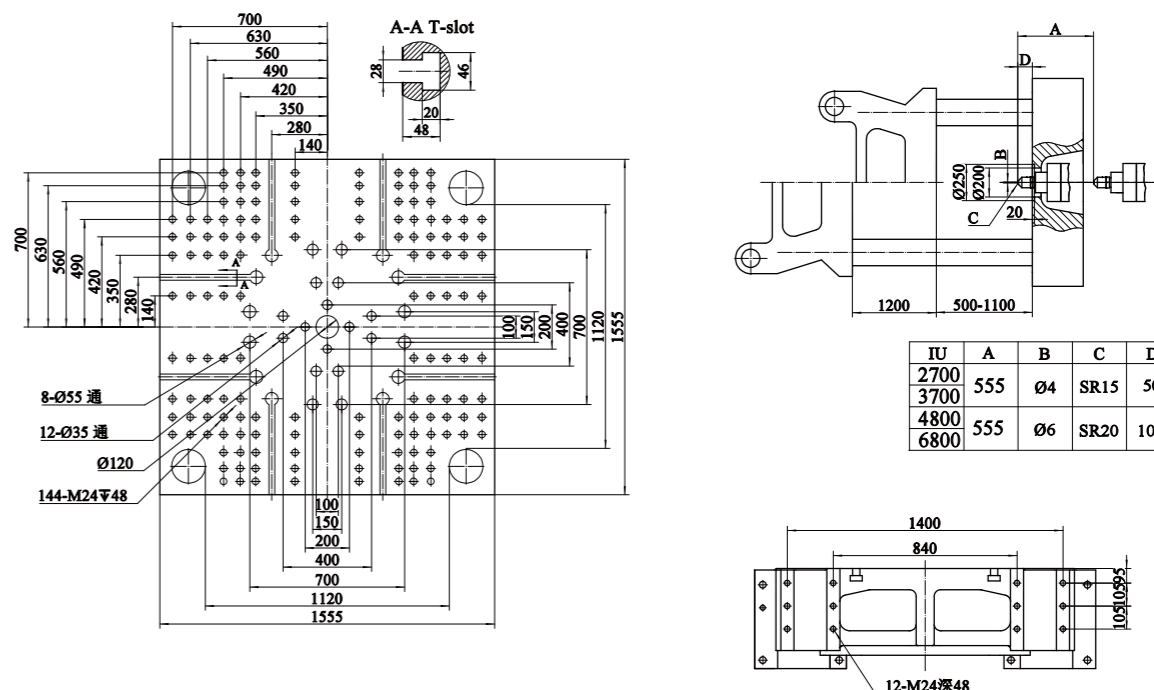

# FF1080

CLAMPING UNIT													
Clamping force	kN	10800											
Mold opening/closing stroke	mm	1300											
Space between tie bars	mm	1320 × 1320											
Mold thickness	mm	500-1200											
Ejector stroke	mm	210											
Ejector force	kN	230											
Number of ejectors		29											
INJECTION UNIT													
Model of injection unit		IU3700			IU4800			IU6800			IU9000		
International specification		3691			4800			6800			9000		
		A	B	C	A	B	C	A	B	C	A	B	C
Screw diameter	mm	76	84	92	84	92	100	92	100	108	100	108	116
Screw L/D ratio		22.1	20	20	21.9	22	21.6	21.7	22	21.5	21.6	22	21.6
Screw stroke	mm	370			400			480			550		
Stroke-bore ratio		4.9	4.4	4.0	4.8	4.3	4.0	5.2	4.8	4.4	5.5	5.1	4.7
Shot volume	cm <sup>3</sup>	1678	2050	2460	2217	2659	3142	3191	3770	4397	4320	5038	5813
Shot weight (PS)	g	1544	1886	2263	2039	2446	2890	2936	3468	4045	3974	4635	5348
Injection pressure	MPa	220	180	150	216	180	152	213	180	154	210	180	156
Holding pressure	MPa	176	144	120	173	144	122	170	144	123	168	144	125
	mm/s	160			160			160			160		
Injection rate	cm <sup>3</sup> /s	726	887	1064	887	1064	1257	1064	1257	1466	1257	1466	1691
Screw speed	rpm	180			150			150			150		
Nozzle contact force	kN	100			100			120			120		
Heating power	kW	33.1	36.1	36.5	41.2	45.0	41.7	47.2	54.1	53.7	58.9	65.9	
Total power	kW	133.3			133.2			168.5			215.6		
Total current	A	259.0			262.7			361.6			516.8		
GENERAL UNIT													
Oil pump motor	kW	51											
Max. system pressure	Mpa	17.5											
System flow	L/min	263											
Oil tank capacity	L	300											

※ The Data above were acquired by testing in the factory, only for your reference.

## FF1080 Machine Dimensions

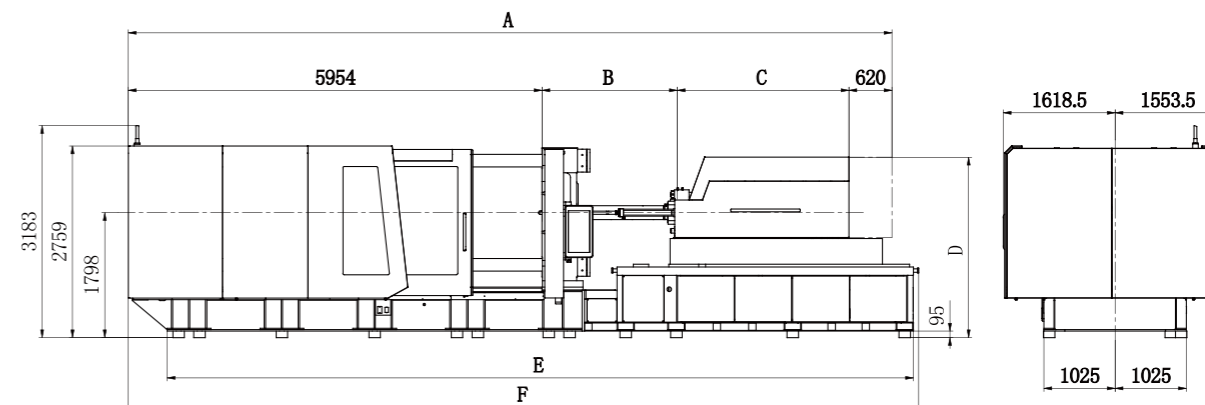

Model	A(A/B/C Screw)	B(A/B/C Screw)	C	D	E	F
IU3700	10992/10992/11152	1953/1953/2113	2465	2609	10740	11375
IU4800	11447/11642/11797	2149/2344/2499	2724	2662		
IU6800	11930/12150/12280.5	2319/2539/2669.5	3037	2667	11340	11975
IU9000	12325/12553/12737	2510/2738/2922	3241	2707	11740	12375

## FF1080 Platen Dimensions

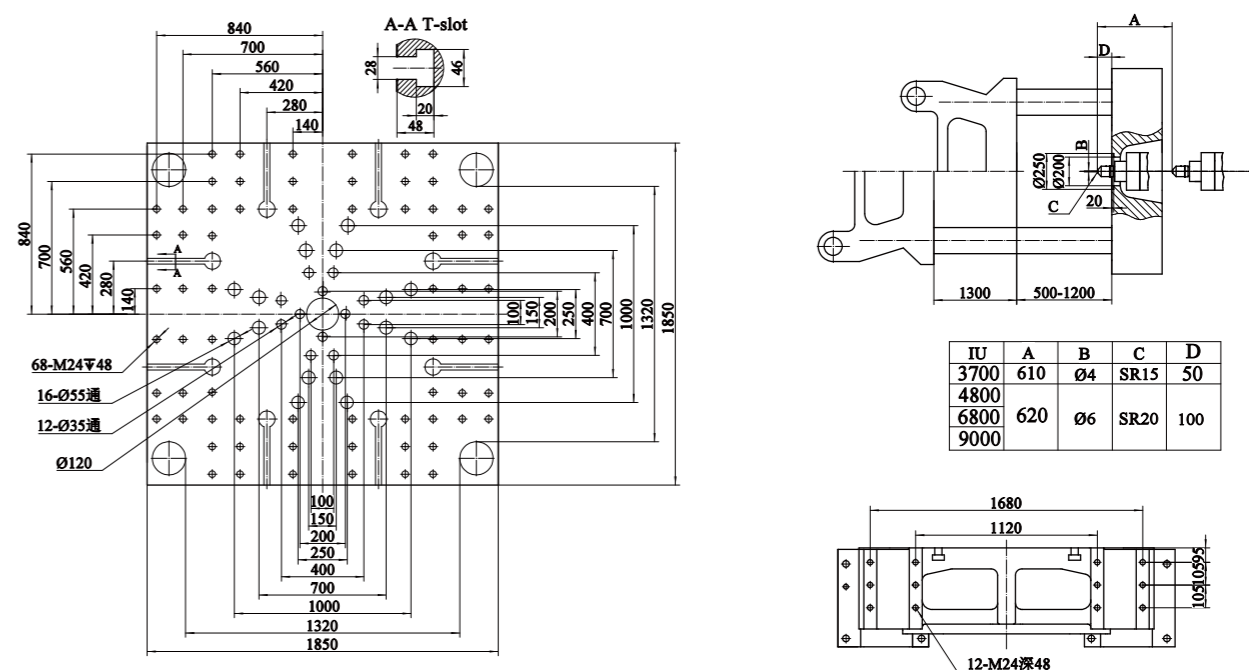



# Standard Features

## Control and monitoring unit

- Highly sensitive 12-inch color touchscreen display
- Memory of molding conditions (over 500 items)
- 1 set of standard USB interface on the operation panel
- Multiple language (Chinese and English)
- Real-time display of injection molding data (200 items displayed; 5000 items saved)
- Operation modification record
- Alarm record
- Electrical control circuit for simple robot
- Metric and English unit conversions
- I/O check display function
- Printer interface (USB 17)
- Cycle time monitoring
- Production management
- PDP data and charts
- Injection quality check
- Cycle counter
- Molding temperature monitoring
- Tri-color alarm light
- Alarm buzzer
- Low-pressure mold protection curve checking
- Injection pressure protection
- Defect alert and handling
- Real-time display of injection and plasticizing servo motion curves
- Display of actual value
- Malfunction handling option selection
- Product quality monitoring
- Curves of mold opening/closing and ejector
- Injection processing curve monitoring

## Clamping unit

- 5-stage mold opening and closing control
- Needle valve/Spure functions (4 sets)
- Multi-stage ejector forward
- Ejector backward delay time monitoring
- Automatic mold height adjustment
- Spure timing control
- Curves of mold open/close and ejector
- Platen with T-slot and mold mounting holes
- Low pressure mold protection (AI highly-sensitive mold protection)
- Low speed, low pressure mold opening / closing in mold adjustment mode
- Ejection inside the mold (gate cutting inside the mold)
- Mold opening during ejector backward
- Ejector backward in place confirmation
- Ejector motion selection (4 modes)
- 3-stage ejector control
- Ejector motion delay
- Mold cooling water distributor
- Embedded dual-size locating ring design (fixed platen)
- Emergency stop function (on both operator side and non-operator side)
- EU standard threaded mounting holes for robot
- Central lubrication system
- Slope control for mold opening and closing (high, medium and low modes)
- Core puller/unscrew function (2 sets of electrical interfaces)
- Air blast (4 sets of electrical interfaces)
- Hydraulic ejector

## Plasticizing and injection unit

- Injection safety device (Test switch)
- 5-stage injection control (pressure, speed, position)
- 3-stage holding pressure control (pressure, speed, time)
- 3-stage plasticizing control (back pressure, speed, position)
- Suck-back control (pre-suckback and post-suckback)
- Injection delay function
- Pre-plasticizing delay
- Holding pressure switching (6 modes)
- Injection speed response setting (High, medium, low)
- Mold opening during plasticizing
- Molding temperature closed-loop control
- Temperature holding
- Temperature optimization
- Synchronized temperature rise
- Appointed temperature rise
- Remaining resin prevention
- Screw cold start prevention
- Automatic material purge
- Calibration of injection pressure zero point
- Real-time display of plasticizing speed
- Real-time display of plasticizing back pressure
- Injection unit shift settings (switch check, shift time)
- High-force nozzle contact device (configurable)
- Nozzle center alignment adjusting device

## Other features

- Color of FF series electric injection molding machine
- Closed safety door
- Adjustable vibration-damping wedge mount
- Hopper sliding device
- Power socket (220V x 1, on clamping unit frame)
- Power socket (380V, 32A x 2, 16A x 1, on the right side of the injection unit frame)
- Common tool kits and spare parts

# Optional Features

## Control and monitoring units

- EU12 electrical interface for robot
- EU 67 electrical interface for robot
- Additional languages
- Cooling water circuit
- Heater burnout detection
- External transformer
- Electrical interface for product sorting device
- Electrical interface for gas assisted injection
- Electrical interface for magnetic platens
- Electrical interface for mold cavity pressure check
- Mold temperature display and control
- OPC UA/DA
- EU 73 electrical interface

## Clamping unit

- Various locating rings
- Core unscrewing device
- Needle valve/spure device
- Air blast device
- Product chute
- Mold thermal insulation plate
- Glass-tube cooling water flowmeter
- Pneumatic ejector
- Pneumatic core puller device
- Increased Maximum daylight
- Mold slide protection
- Injection compression (clamping synchronized with injection)

## Plasticizing and injection unit

- Dedicated barrel unit
- Extended nozzle
- Spring shut-off nozzle
- Stainless steel hopper (max. load of 50kg dry material)
- Barrel heat-retaining energy-saving device
- Ceramic heater band
- Mold internal pressure V/P switching
- Needle valve pneumatic injection nozzle
- High capacity injection nozzle heating band
- Customized nozzle head

## Other features

- Hopper sliding device (on wheels)
- Barrel heat-retaining energy-saving device
- Auxiliary electrical cabinet
- Vacuum air extractor
- Quality control sorting device
- Integrated multi-stage mold temperature control

### ■ Disclaimer:

1. The company reserves the right to improve the products described in the brochure, specifications are subject to change without notice.
2. The product photos are for reference only, which are subject to the actual products.
3. The data are obtained from Yizumi's laboratory test, and the final interpretation right belongs to Yizumi.